

POWER MANAGEMENT

Power Efficient EL Lamp Driver

The IMP560 is an Electroluminescent (EL) lamp driver designed for systems with low EL lamp drive voltage requirements. It is ideal for low ambient light applications or where small lamps are used. With just one-half the inductor current of the IMP803, the IMP560 reduces system power consumption and extends battery life. Input supply voltage range is 2.0V to 6.5V and quiescent current is a low 420 μ A. Typical EL lamp drive voltage is \pm 56V.

All four EL lamp-driving functions are on-chip. These are the switch-mode power supply, its high-frequency oscillator, the high-voltage H-bridge lamp driver and its low-frequency oscillator. EL lamps of up to 6nF capacitance can be driven to high brightness.

The circuit requires few external components; a single inductor, a single diode, two capacitors and three resistors. Two of these resistors set the frequencies for two internal oscillators. An internal circuit shuts down the switching regulator when the lamp drive voltage exceeds 120V peak-to-peak. This conserves power and extends battery life.

A disable mode puts the chip into a low current drain mode. With a 3.0V supply, quiescent current drops to 200nA maximum, 50nA typical. The chip is disabled by connecting the oscillator frequency setting resistor R_{SW} to ground.

The IMP560 is available in MicroSO and SO-8 packages and in die or wafer form.

Key Features

- ◆ 112V peak-to-peak typical AC output voltage
- ◆ Low input current (w/inductor current).....12mA
- ◆ Low disabled input current.....50nA
- ◆ Wide operating voltage range - from 2.0V to 6.5V
- ◆ Simple design requires few passive components
- ◆ Adjustable output lamp frequency controls lamp color and power consumption
- ◆ Adjustable converter frequency for minimum power consumption
- ◆ IMP803 pin-compatible
- ◆ MicroSO package option

Applications

- ◆ Night lights
- ◆ Automotive displays
- ◆ Cellular phones
- ◆ Pagers
- ◆ Clocks and radios
- ◆ Portable GPS receivers
- ◆ LCD module backlights

Block Diagram

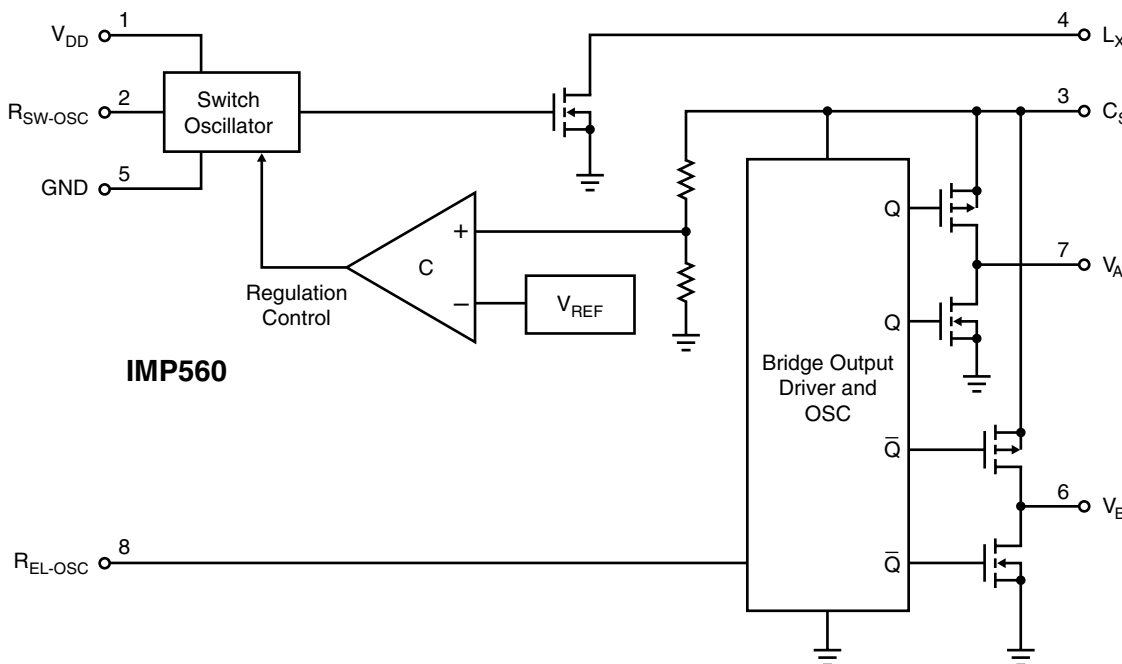

Pin Configuration

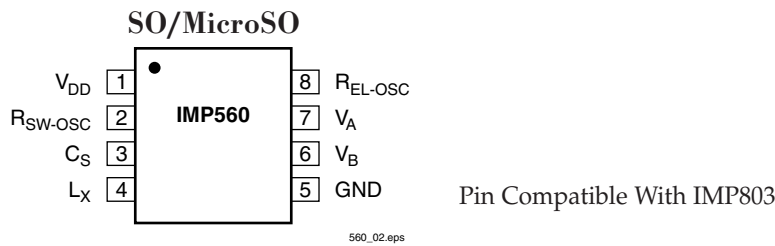

Ordering Information

Part Number	Input Voltage	Regulated Output Voltage	Temperature Range	Pins-Package
IMP560EMA	2.0V to 6.5V	YES	-40°C to +85°C	8-MicroSO
IMP560ESA	2.0V to 6.5V	YES	-40°C to +85°C	8-SO
IMP560/D	2.0V to 6.5V	YES	25°C	Dice

Absolute Maximum Ratings

Supply Voltage, V_{DD} , $V_{RSW-OSC}$ and $V_{REL-OSC}$. . .	-0.5V to +7.0V
Output Voltage, V_{CS}	-0.5V to +120V
Operating Temperature Range	-40°C to +85°C
Storage Temperature Range.	-65°C to +150°C
Power Dissipation (SO)	400mW
Power Dissipation (MicroSO)	300mW

Note: All voltages are referenced to GND.

These are stress ratings only and functional operation is not implied. Exposure to absolute maximum ratings for prolonged time periods may affect device reliability.

Electrical Characteristics

Unless otherwise noted, $V_{DD} = 3.0V$, $R_{SW} = 750k\Omega$, $R_{EL} = 2.0M\Omega$, and $T_A = 25^\circ C$.

Parameter	Symbol	Conditions	Min	Typ	Max	Units
ON-resistance of MOS Switch	$R_{DS(ON)}$	$I = 100mA$		3.5	8	Ω
Output Voltage Regulation	V_{CS}	$V_{DD} = 2.0$ to $6.5V$	52	56	65	V
Output Voltage Peak-to-peak (in regulation)	$V_A - V_B$	$V_{DD} = 2.0$ to $6.5V$	104	112	120	V
Quiescent V_{DD} Supply Current, Disabled	I_{DDIS}	$V_{RSW-OSC} < 100mV$		50	200	nA
Input Current at V_{DD} Pin	I_{DD}	$V_{DD} = 3.0V$, See Figure 1		470	700	μA
Input Current at V_{DD} Pin	I_{DD}	$V_{DD} = 5.0V$, See Figure 2		500	750	μA
Input Current: I_{DD} Plus Inductor Current	I_{IN}	$V_{DD} = 3.0V$, See Figure 1		12		mA
$V_{A,B}$ Output Drive Frequency	f_{EL}	$V_{DD} = 3.0V$, See Figure 1	300	370	430	Hz
Switching Frequency	f_{SW}	$V_{DD} = 3.0V$, See Figure 1	50	70	90	kHz
Switching Duty Cycle	D_{SW}	$V_{DD} = 3.0V$, See Figure 1		88		%

Typical Characteristics

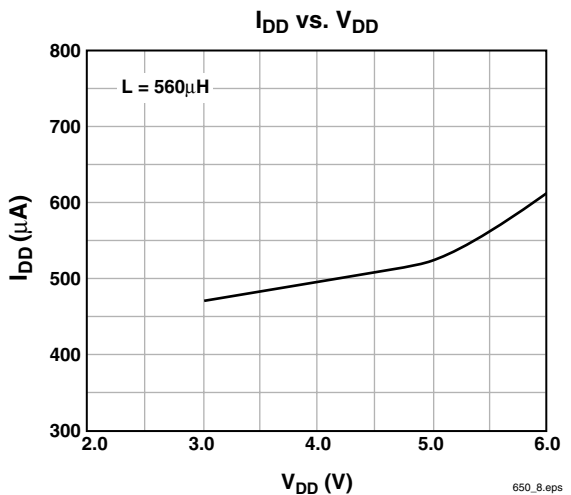
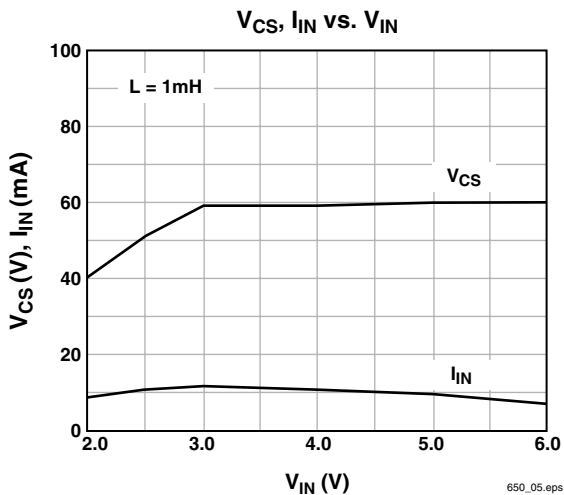
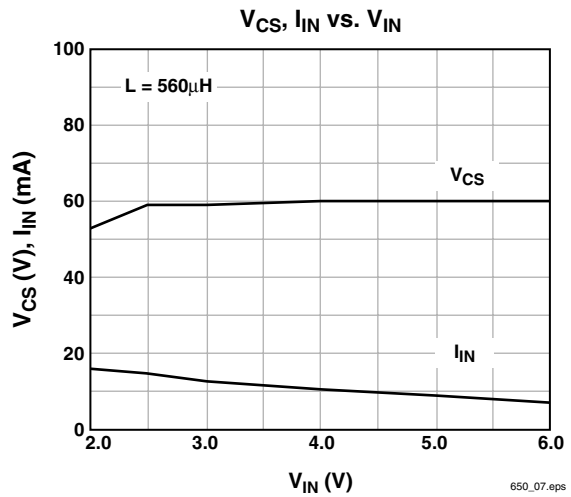
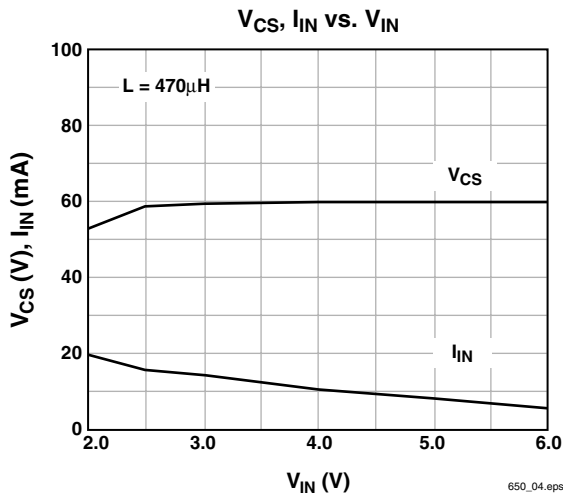
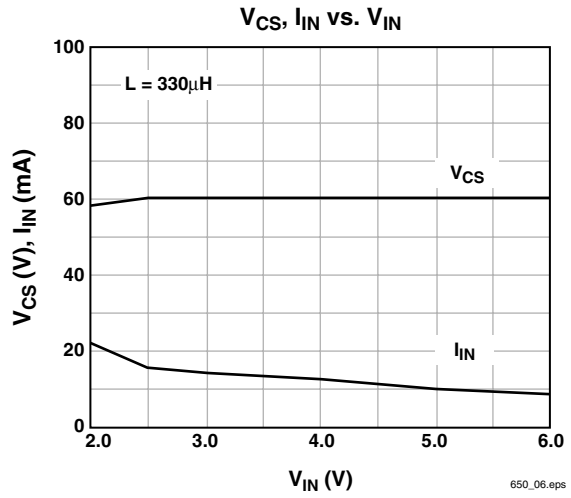
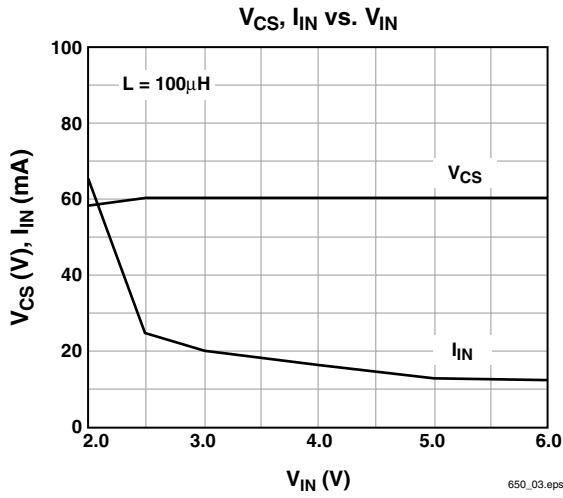

Pin Descriptions

Pin Number	Name	Function
1	V_{DD}	Positive voltage supply for the IMP560. Inductor L may be connected here or to a separate unregulated supply.
2	R_{SW-OSC}	Switch-mode resistor pin. Switching frequency is determined by an external resistor, R_{SW} .
3	C_S	Boost converter storage capacitor. The voltage across the EL lamp is equal to twice the voltage at C_S .
4	L_X	Connection to flyback inductance, L.
5	GND	Ground pin.
6	V_B	EL lamp drive. The lamp is connected in a high-voltage bridge circuit with V_B providing the complementary connection to V_A . The peak-to-peak AC voltage across the EL lamp is thus two times V_{CS} .
7	V_A	EL lamp drive. (See above)
8	R_{EL-OSC}	The EL lamp oscillator frequency setting pin. The oscillator frequency is controlled by external resistor R_{EL} .

External Components

External Component	Description and Selection Guide
Diode	A fast reverse recovery diode, with $BV > 100$, such as a 1N4148.
Capacitor C_S	This is the high voltage capacitor that stores the inductive energy transferred through the diode. A 100 volt capacitor between 10nF and 100nF is recommended.
Resistor R_{EL}	The EL lamp oscillator frequency setting resistor. This resistor, connected between the R_{EL-OSC} pin and ground, provides an oscillator frequency inversely proportional to R_{EL} ; as R_{EL} increases, the EL lamp frequency decreases along with the current drawn by the lamp. Lamp color is also determined by this frequency. A 2M Ω resistor between the R_{EL-OSC} pin and the V_{DD} supply results in a lamp frequency around 350Hz: a 1M Ω resistor will give ≈ 700 Hz.
Resistor R_{SW}	Switching Oscillator frequency setting resistor. The switching oscillator resistor is connected between the R_{SW-OSC} pin and the V_{DD} supply. The switching frequency is inversely proportional to the resistor value, dropping as the resistance increases.
Inductor L	<p>The inductor provides the voltage boost needed by means of inductive “flyback”. The internal MOSFET switch alternately opens and closes the ground connection for the inductor at the L_X pin. When this internal switch opens, the inductor potential will forward-bias the diode and the current will pass through the storage capacitor C_S, charging it to a high voltage.</p> <p>Smaller inductors are preferred to prevent saturation. As the value of the inductor increases (and the series DC resistance of the inductor decreases), the switching frequency set by R_{SW} should be increased to prevent saturation. In general, smaller value inductors that can handle more current are more desirable when larger area EL lamps must be driven.</p>

Test and Application Circuit, 3.0V

Figure 1 shows the IMP560 configured to drive a 3-square-inch EL lamp, represented as a 10nF capacitor.

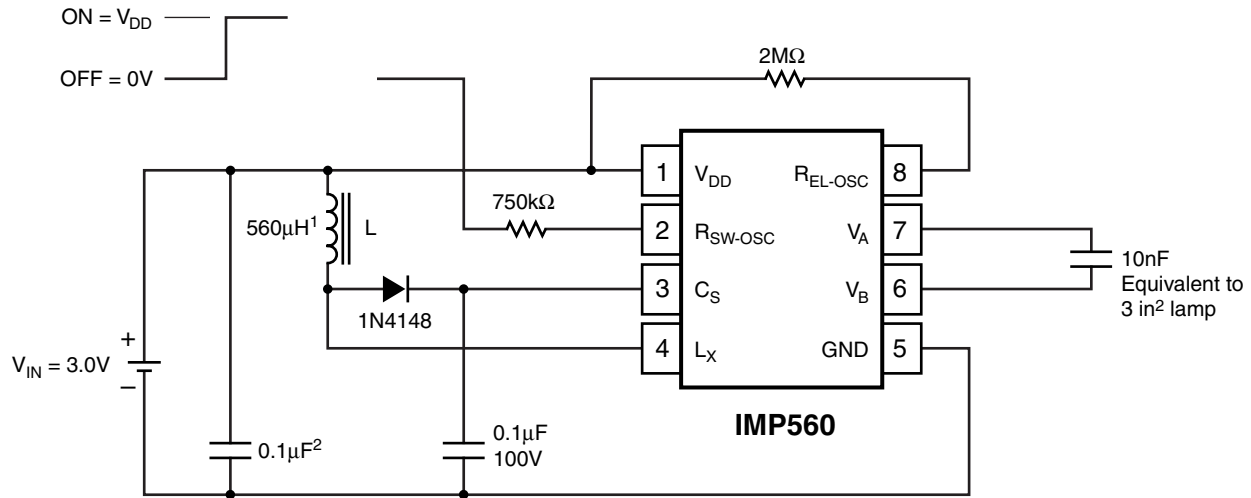

- Note:
1. Murata part # LQH4N561K04 (DC resistance <math>< 14.5\Omega</math>)
 2. Larger values may be required depending upon supply impedance.

560_09.eps

Figure 1. 3.0V Application

Test and Application Circuit, 5.0V

Figure 2 shows a 5.0V input application driving a 6-square-inch EL lamp.

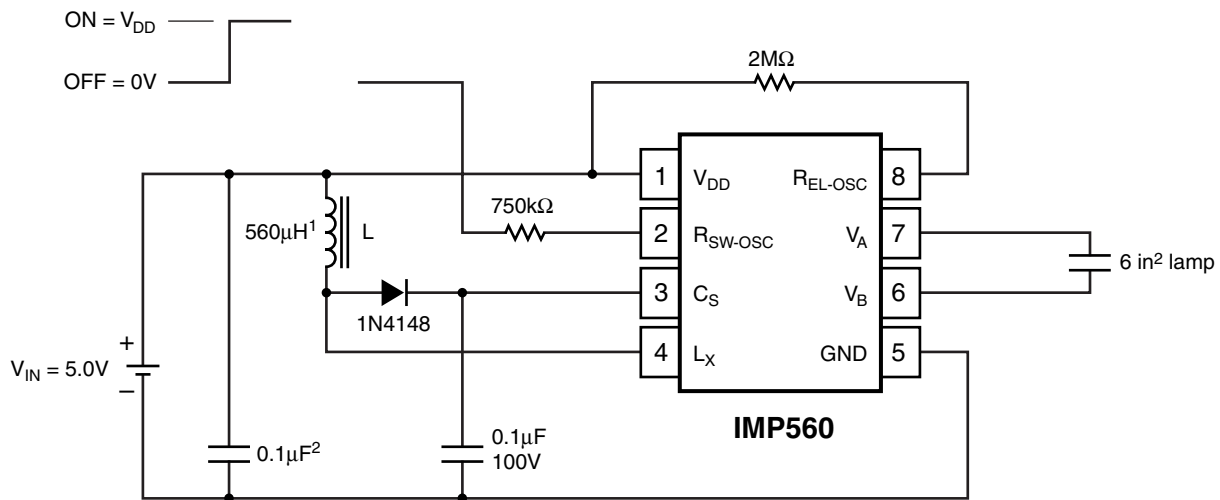

- Note:
1. Murata part # LQH4N561K04 (DC resistance <math>< 14.5\Omega</math>)
 2. Larger values may be required depending upon supply impedance.

560_10.eps

Figure 2. 5.0V Application

Enable/Disable Operation

Figure 3 shows the IMP560 can be enabled via a logic gate that connects R_{SW} to V_{DD} , and disabled by connecting it to ground. R_{EL} may be connected either to V_{DD} or to the gate.

Enable/Disable Table	
R_{SW} Connection	IMP560 State
V_{DD}	Enabled
Ground	Disabled

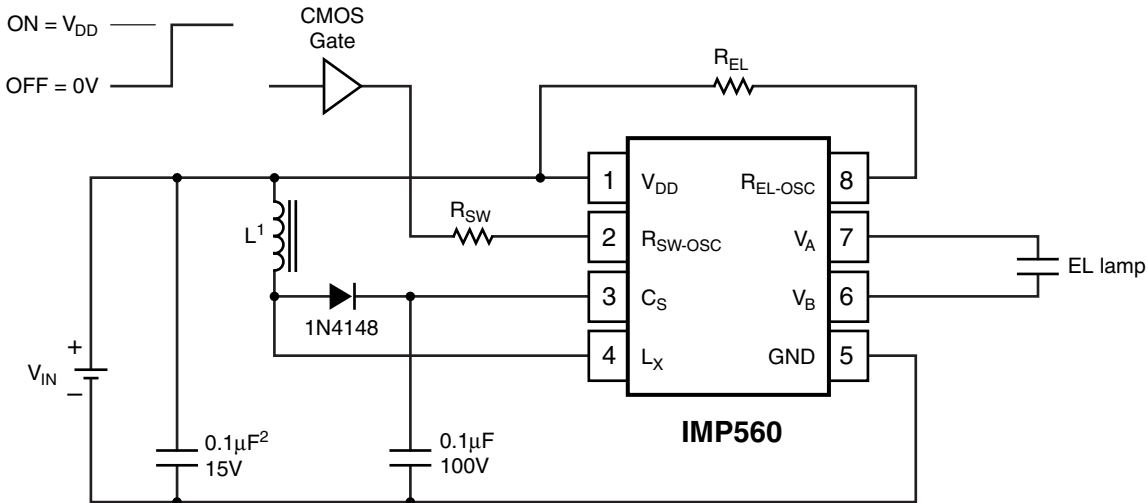

Note:

1. Murata part # LQH4N561K04 (DC resistance <math>< 14.5\Omega</math>)
2. Larger values may be required depending upon supply impedance.

560_11.eps

Figure 3. Enable/Disable Operation

Dual Supply Operation with 1.5V Battery

The IMP560 can also be operate from a single battery cell when a regulated voltage higher than 2.0V is also available. The dual supply configuration, shown in Figure 4, uses the regulated voltage to operate the IMP560 while the energy for the high-voltage boost circuit comes from the battery. The current to run the internal logic is typically 420µA.

The circuit of Figure 4 can also be used with batteries that exceed 6.0V as long as V_{DD} does not exceed 6.5V.

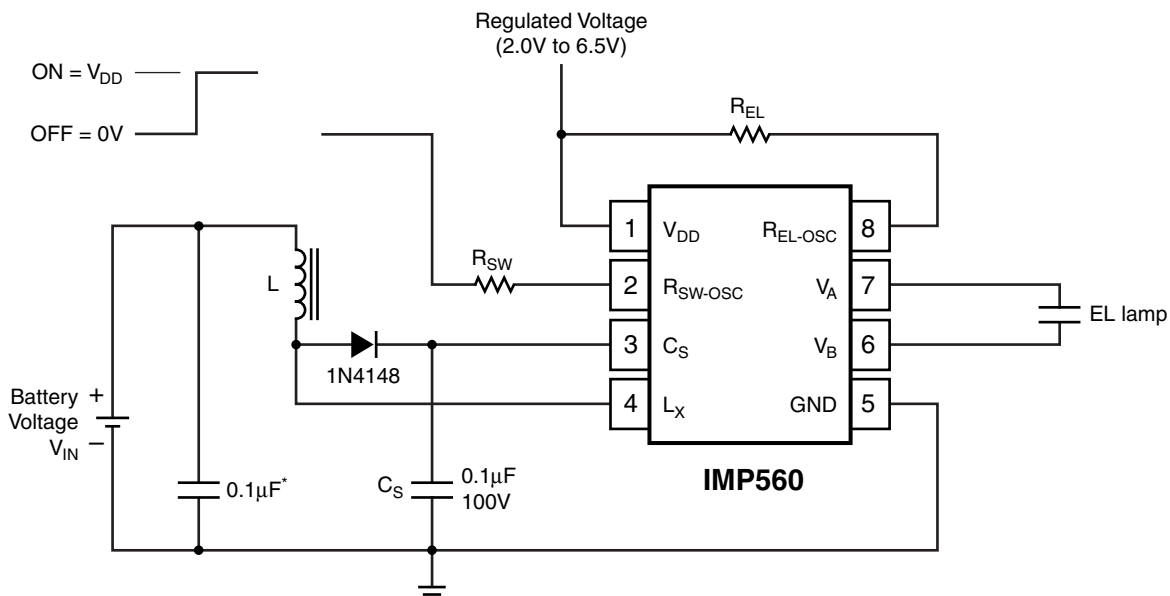

* Larger values may be required depending upon supply impedance

560_12.eps

Figure 4. Dual Supply Operation with High Battery Voltages

Package Dimensions

SO (8-Pin)

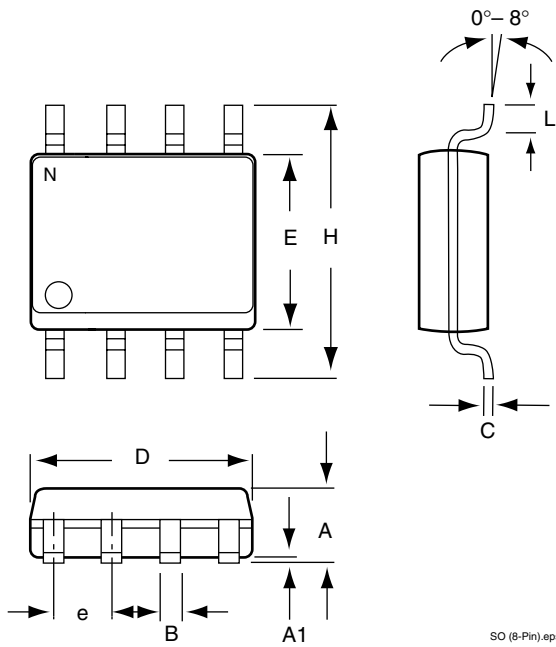

MicroSO (8-Pin)

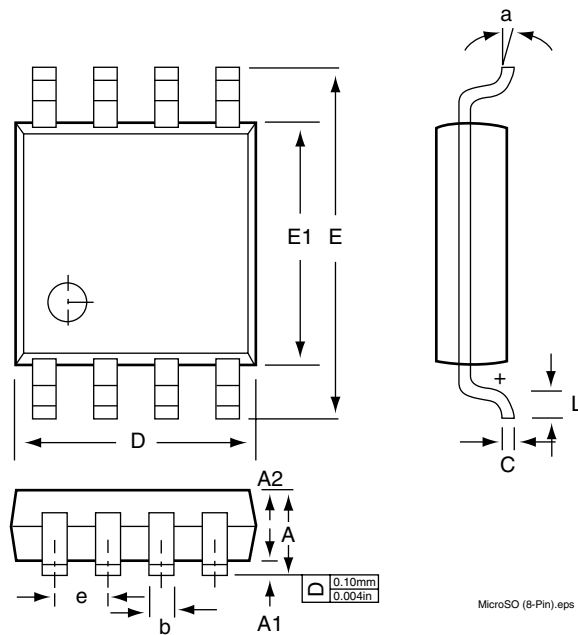

	Inches		Millimeters	
	Min	Max	Min	Max
SO (8-Pin)*				
A	0.053	0.069	1.35	1.75
A1	0.004	0.010	0.10	0.25
B	0.013	0.020	0.33	0.51
C	0.007	0.010	0.19	0.25
e	0.050		1.27	
E	0.150	0.157	3.80	4.00
H	0.228	0.244	5.80	6.20
L	0.016	0.050	0.40	1.27
D	0.189	0.197	4.80	2.00
MicroSO (8-Pin)**				
A	—	0.0433	—	1.10
A1	0.0020	0.0059	0.050	0.15
A2	0.0295	0.0374	0.75	0.95
b	0.0098	0.0157	0.25	0.40
C	0.0051	0.0091	0.13	0.23
D	0.1142	0.1220	2.90	3.10
e	0.0256 BSC		0.65 BSC	
E	0.193 BSC		4.90 BSC	
E1	0.1142	0.1220	2.90	3.10
L	0.0157	0.0276	0.40	0.70
a	0°	6°	0°	6°

* JEDEC Drawing MS-012AA

** JEDEC Drawing MO-187AA

803_101.at3

High-Voltages Present

The IMP560 generates high voltages and caution should be exercised.



IMP, Inc.
Corporate Headquarters
2830 N. First Street
San Jose, CA 95134-2071
Tel: 408-432-9100
Tel: 800-438-3722
Fax: 408-434-0335
e-mail: info@impinc.com
<http://www.impweb.com>